

Principal Applications

Designed for continuous operation in, chillers, coolers, vending and general water applications

Pipes, Fittings and Mounting Plates

SPC pumps are fitted to python systems to provide the optimum cooling rate for soft drinks, beers and wines

Braided hose or brewery tubing complete with fittings available to order
Alternative mounting plates in stainless steel available to order

Wetted Materials

PP or stainless steel mounting plate
Glass filled ABS Column & Pump Body with PP Impellers,
Stainless steel shaft & Nylon Agitator

Features

Up to 16 litres/minute,
Up to 18.3 metres head
Low maintenance and long life
Available with plugs and leads to suit application
Agitator propeller fitted as standard
Top mounted with keyhole mounting plate
IPX5 motor housing
Three stage pump head

SPC53 Voltage

110V or 230V 50/60Hz versions

Installation

Drawings not to scale
Dimensions in millimetres

SPC53

Supplied with 0.5m bare lead
Customer options available

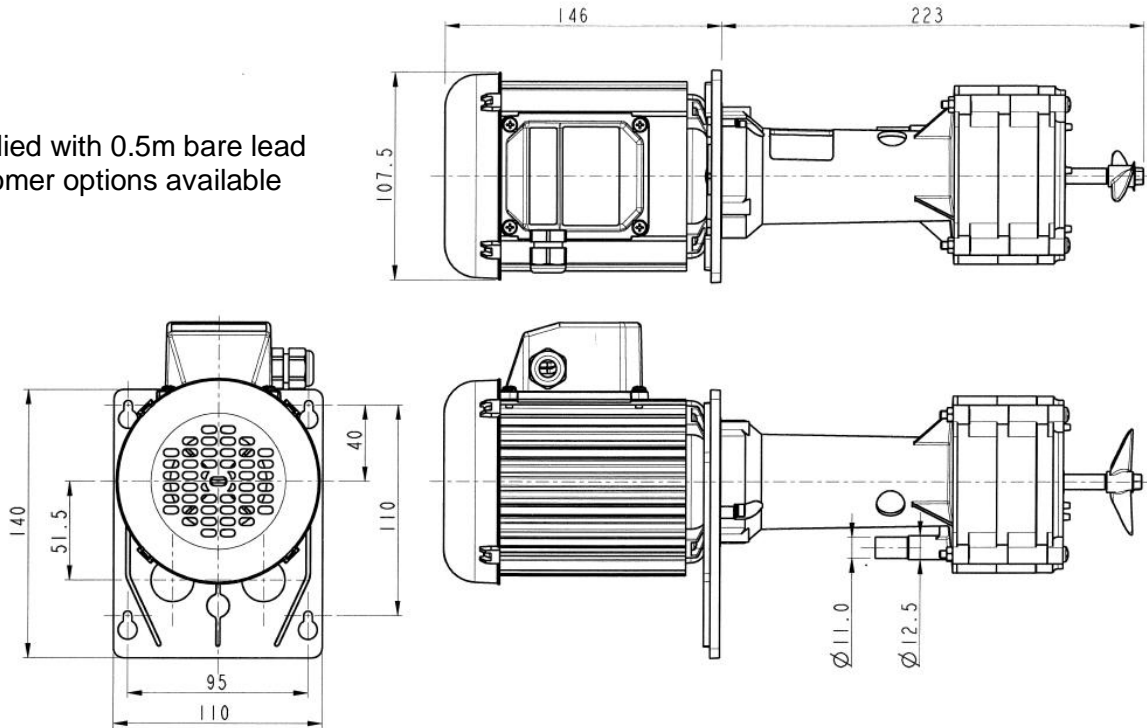

Specification

Model	Overall height (mm)	Overall length (mm)	Weight (kg)	Run-out flow rate (l/min)	Closed valve head (m)	Output port (mm)	Temp range (degC)	*Max specific gravity	Motor output (watts)
SPC53	146	369	3.3	50Hz 16	18.3	Plain 11/12.5 combined	-20 to +85	1.0	90
				60Hz 17.2	24.5				

*Assuming maximum viscosity of 30cp. Refer to Totton Pumps for higher viscosities and specific gravities

Performance

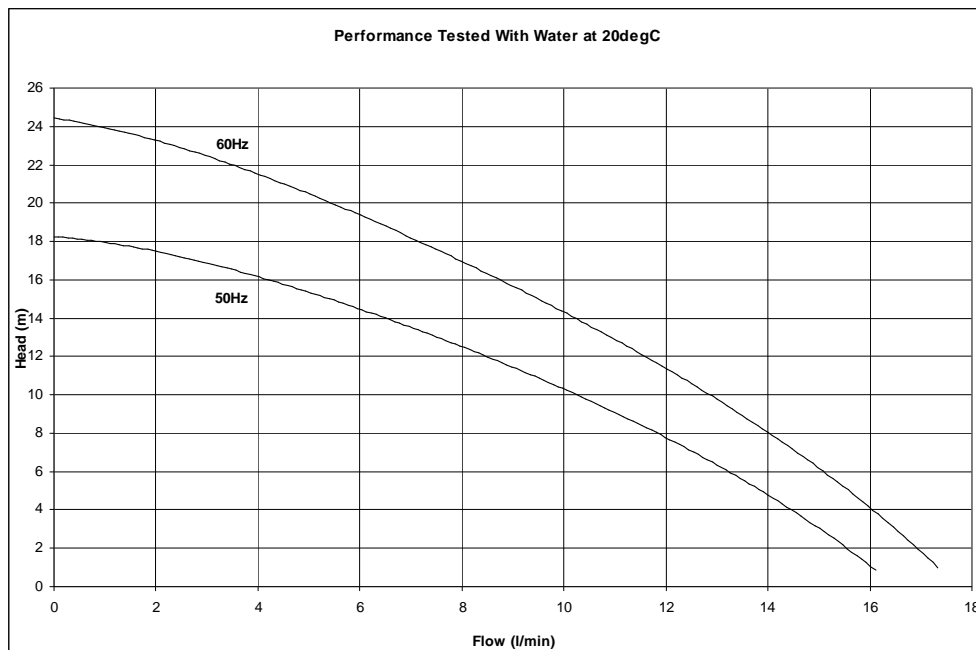

NOTE: These pumps are designed for use with clean fluids.
Solids will cause jamming. Abrasives will reduce pump life & invalidate the warranty.
SPC pumps are self-priming. The company reserves the right to change specifications

Totton Pumps Ltd.

Tel: +44 (0)23 8066 6685
Email: info@totton-pumps.com

Fax: +44 (0)23 8066 6880
Web: totton-pumps.co.uk