

Principal applications

For applications requiring safe, high-head, leak-free continuous flow of aggressive chemicals, acids, alkalis, sterile & chilled fluids.

Wetted materials

Standard EPDM 'O' ring, optional Viton
PP encapsulated magnet
PP pump housing
PPS spindle housing
Alumina ceramic spindle

Features

Manufactured in chemical resistant thermoplastics - entirely non-metallic

Pump head can be connected in series for high head applications.

Can pump two dissimilar fluids simultaneously.

Magnetic couplings provide an energy efficient thermal shield, minimising heat transfer to pumped fluids.

IP 54 motor housing standard.

Deep groove ball bearings

NEMP 50/11

230V 1ph 50Hz
230V 1ph 50Hz
230V 1ph 60Hz
230V 1ph 60Hz

Port Details

Plain 15mm
3/8" BSP M
Plain 15mm
3/8" BSP M

NEMP 50/11

110V 1ph 50Hz
110V 1ph 50Hz
110V 1ph 60Hz
110V 1ph 60Hz

Port Details

Plain 15mm
3/8" BSP M
Plain 15mm
3/8" BSP M



Drawings not to scale
 Dimensions in millimetres

NEMP 50/11

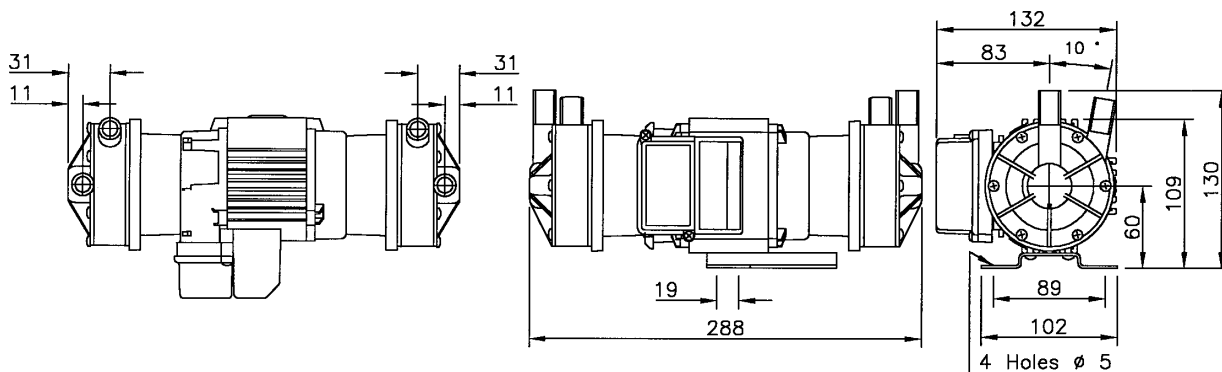

Specification

Model	Overall height mm	Overall length mm	Overall width mm	Weight kilos	Max body pressure bar	Max capacity litres/min	Max head metres	Temp range °c	*Max specific gravity	Motor output Watts
NEMP 50/11	130	288	132	3.8	1.4	50	11	-20° to +85°	1.2	100

*assuming maximum viscosity of 30cp. Refer to the Company for higher viscosities & specific gravities

Performance Tested with clean cold water @ 20° c

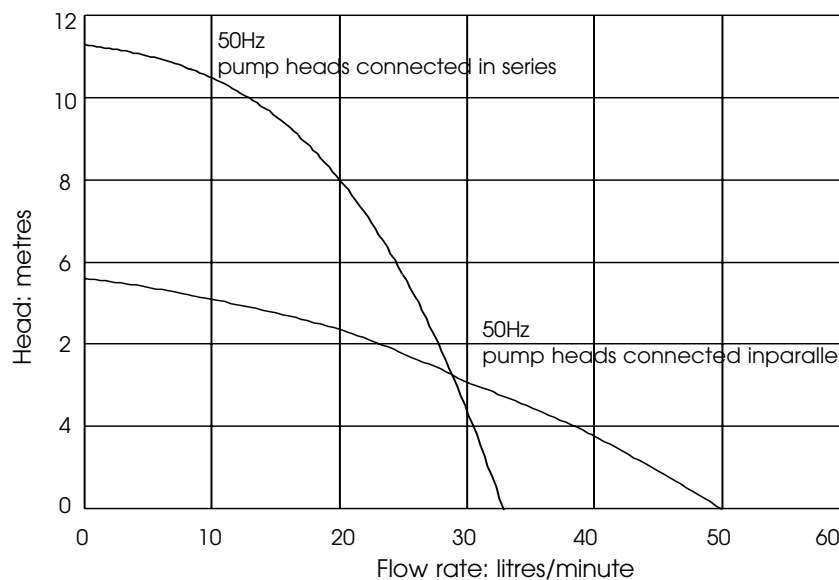

NOTE: These magnetically coupled pumps are designed for use with clean fluids. Solids will cause jamming. Abrasives will reduce pump life & invalidate the warranty. NEMP pumps are not self-priming & are not designed to run dry.

The company reserves the right to change specifications

a division of *the* Electric Motor Company Limited

phone+44 (0)23 8066 6685
 fax+44 (0)23 8066 6880
 email: info@totton-pumps.com
 www.totton-pumps.co.uk